

ST1325N

Pull Type Tubular Solenoid

0.50" Dia. × 1.03" L
(12.7mm × 26.2mm)



Specifications:

- Operation: Pull
- Insulation: Class "A" (105°C) standard*
- Coil Termination: 26 AWG flying leads per drawing*
- Plunger linkage: Slot & cross-drilled*
- Plunger pole face: 45° conical*
- Solenoid weight: 0.81oz [23g]
- Plunger weight: 0.17oz [4.9g]
- Dielectric Strength: 1000VAC for one minute
- Operating temperature range: -20°C to 40°C

*Other options available upon request

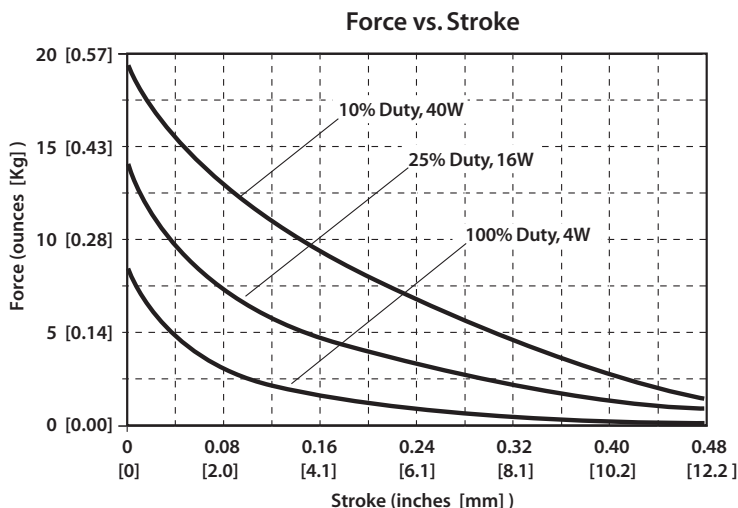

Coil Data:

Voltage (VDC)	100% Duty — 4W		25% Duty — 16W		10% Duty — 40W	
	Resistance (Ω)	Part Number	Resistance (Ω)	Part Number	Resistance (Ω)	Part Number
3	2.3	ST1325N0300	0.56	ST1325N0325	0.23	ST1325N0310
6	9.0	ST1325N0600	2.3	ST1325N0625	0.9	ST1325N0610
12	36.0	ST1325N1200	9.0	ST1325N1225	3.6	ST1325N1210
24	144	ST1325N2400	36.0	ST1325N2425	14.4	ST1325N2410

Typical force @20°C and nominal rated DC voltage. Resistance values ±10% @20°C. All data subject to change. Other voltages and duty cycles available upon request.

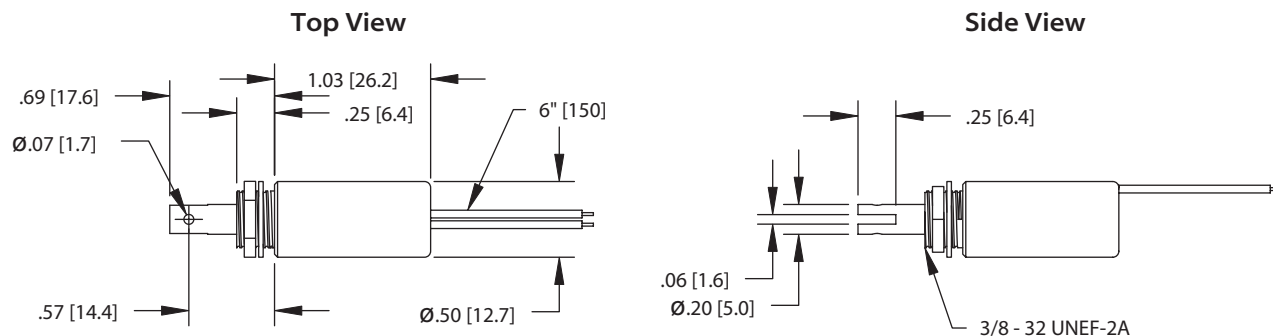

Notes: Solenoid shown in energized position. Dimensions listed are for reference only. Dimensions shown in inches and [mm].